

KDT 3.60

Rotary vane compressors

- oil-free and air-cooled
- incl. integrated suction filter and pressure regulating valve

Drehschieber-Verdichter

- trockenlaufend und luftgekühlt
- inkl. integriertem Ansaugfilter und Druckregulierventil

Compresseur à palettes

- fonctionnant à sec et refroidies par air
- incl. filtre d'aspiration intégré et soupape de regulege pression

Compressori a palette

- funzionanti a secco e raffreddate ad aria
- incl. filtro di aspirazione integrato e valvola regolazione pressione

Compresores de paletas

- sin aceite y refrigerado por aire
- incl. filtro de aspiración integrado y válvula reguladora de presión



fig.: KDT 3.80

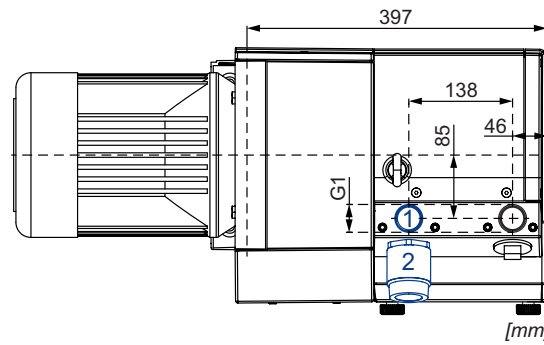
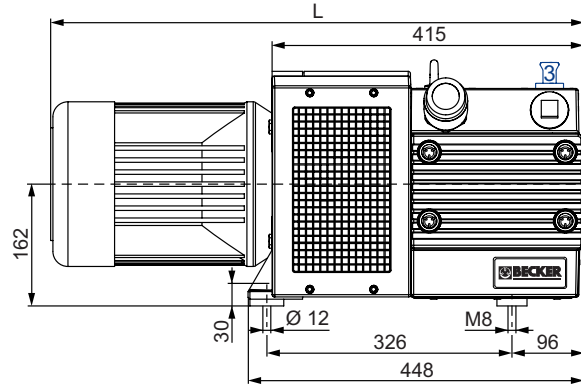
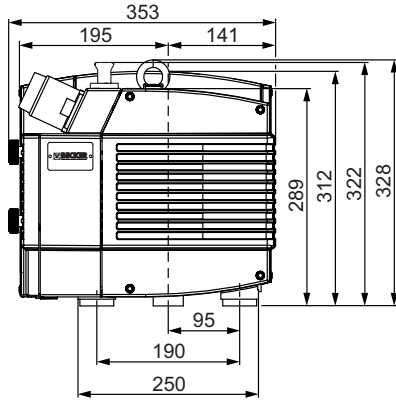

[mm]

- 1 Pressure connection
Druckanschluss
Raccord pression
Raccordo pressione
Conexión de presión
- 2 Pressure regulating valve
Druckregulierventil
Soupape de regulege pression
Valvola regolazione pressione
Válvula reguladora de presión
- 3 Air nozzle
Ansaugdüse
Buse d'aspiration
Ugello di aspirazione
Boquilla de aire

m³/h		bar rel. ¹)		kW 3~		Ⓜ	kg	dB(A)²)	
50 Hz	60 Hz	50 Hz	60 Hz	50 Hz	60 Hz			50 Hz	60 Hz
54	63	+0.5	+0.5	2.4	3.0	1	47 + Ⓜ	71	73
		+1.0	+1.0	2.4	3.0	1	47 + Ⓜ	72	74
		+1.5	+1.5	3.0	3.6	2	47 + Ⓜ	72	74

Ⓜ	kW		V ±10%		min⁻¹		A		kg	no. IP55 • ISO F • bimetal	L mm	no. KDT + Ⓜ		
	50 Hz	60 Hz	50 Hz	60 Hz	50 Hz	60 Hz	50 Hz	60 Hz						
1	2.4	3.0	Δ 230 / Y 400 IE2	Δ 265 / Y 460 IE2	Δ 230 / Y 400	1450	1740	9.3/5.4	9.8/5.7	11.4/6.6	29	42279422300003RE	704	G017352 (+0.5bar) G017115 (+1.0bar)
	-	3.0	-	YY 230 / Y 460 IE2 + UL/CSA	usable @ 208	-	1735	-	10.8/5.4	11.6	26.5	42379407300114TA	689	G017825 (+0.5bar) G018134 (+1.0bar)
	2.4	3.0	Δ 200 / Y 350	Δ 220 / Y 380-400 IE2	Δ 200 / Y 350	1450	1740	11.4/6.6	11.1/6.4-6.1	12.2/7	29	42279453300003RE	704	G017826 (+0.5bar) G018135 (+1.0bar)
	-	3.0	-	Δ 400 / Y 690 IE2	-	-	1740	-	6.1/3.5	-	29	42379454300003RE	704	G017824 (+0.5bar) G018133 (+1.0bar)
2	3.0	3.6	Δ 230 / Y 400 IE2	Δ 265 / Y 460 IE2	Δ 230 / Y 400	1435	1720	11.1/6.4	10.9/6.3	11.8/6.8	29	42479422300003RE	739	G017090
	-	3.6	-	YY 230 / Y 460 IE2 + UL/CSA	usable @ 208	-	1740	-	13.4/6.7	14.3	31.5	42579407300114TA	689	G018281
	3.0	3.6	Δ 200 / Y 350	Δ 220 / Y 380-400 IE2	Δ 200 / Y 350	1425	1720	13.5/8	13.3/7.7-7.3	14.6/8.4	29	42479453300003RE	739	G018282
	-	3.6	-	Δ 400 / Y 690 IE2	-	-	1720	-	7.8/4.6	-	29	42579454300003RE	739	G018280

1) bar relative

bar relativ

bar relatif

bar relativo

bar relativa

2) DIN EN ISO 3744 (KpA = 3 dB(A))
interval of 1m, at medium load, both
connection sides piped

DIN EN ISO 3744 (KpA = 3 dB(A))
Abstand von 1m, bei mittlerer
Belastung, beide Seiten abgeleitet

DIN EN ISO 3744 (KpA = 3 dB(A))
intervalle de 1m, à régime moyen,
avec dérivation des deux côtés

DIN EN ISO 3744 (KpA = 3 dB(A))
intervallo di 1m, a medio regime,
entrambi i lati derivati

DIN EN ISO 3744 (KpA = 3 dB(A))
intervalo de 1m, en media carga,
derivados de ambos lados

• Dimensions in mm

Maßangaben in mm

Mesures en mm

Misure in mm

Dimensiones en mm



WWW.BECKER-INTERNATIONAL.COM

Right of modification reserved
Änderungen vorbehalten
Sous réserve des modifications
Sotto riserva di modificazioni
Derecho a modificaciones reservado

30.06.2014

Blast air rate • Blasluftmenge • Débit d'air soufflé • Volume d'aria soffiata • Volumen de aire soplado

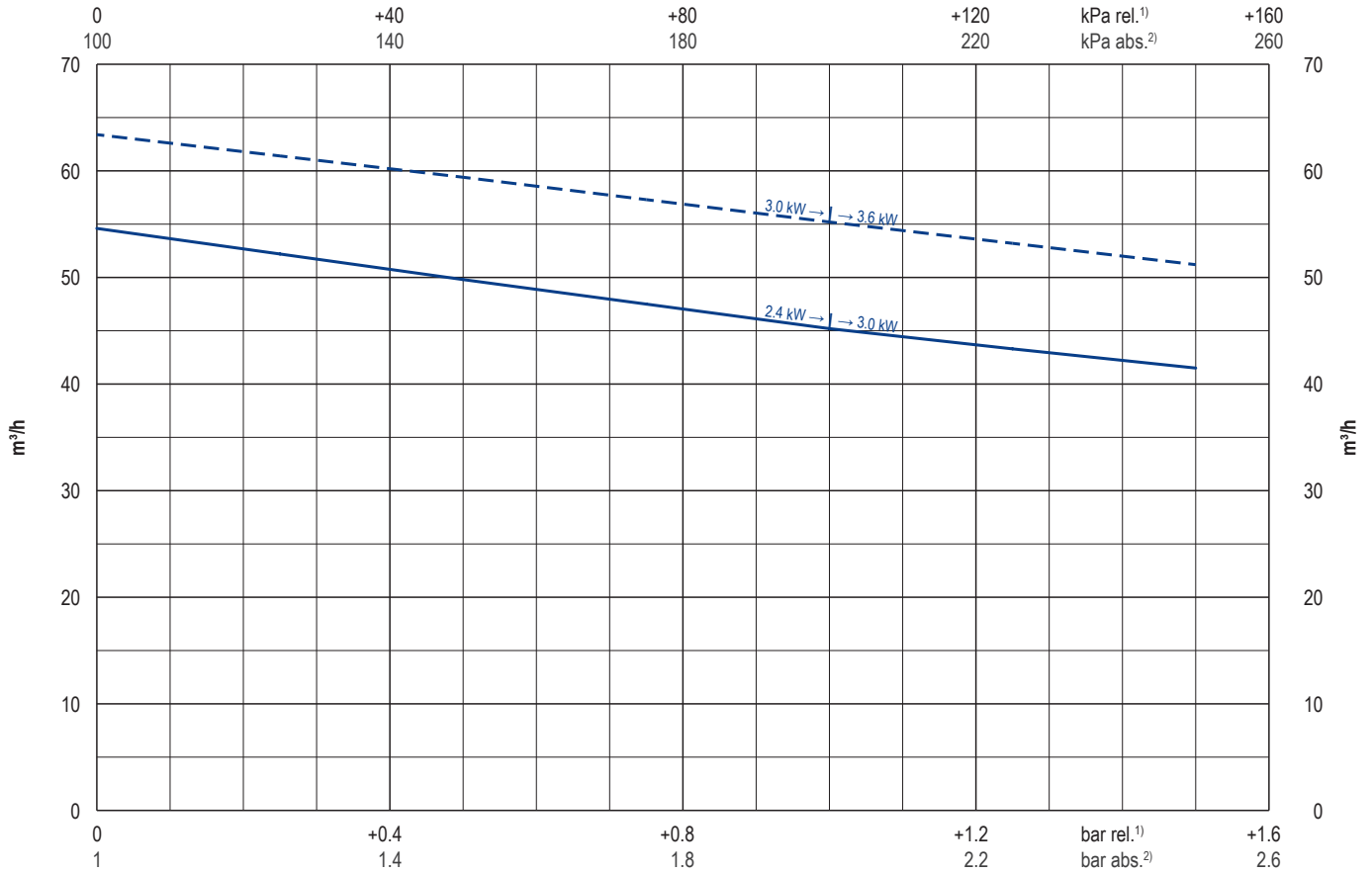

Exhaust air temperature • Ablufttemperatur • Température d'air à l'échappement
Temperatura dell'aria scarica • Temperatura del aire de escape

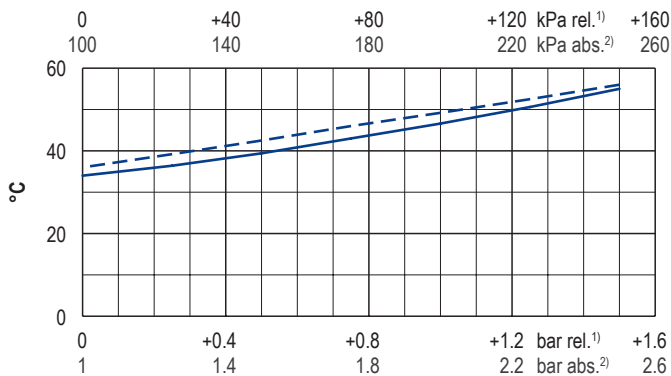

Motor shaft power • Wellenleistung • Puissance du moteur axe
Potenza del motore albero • Capacidad de eje del motor

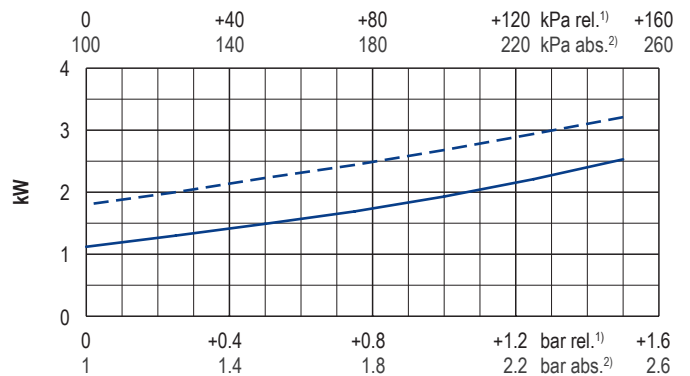

— 50 Hz
- - - 60 Hz

1) relative relativ relatif relativo relativa
2) absolute absolut absolu assoluto assoluta

• Reference data Bezugsdaten Référence Riferimento Referencia 1000 mbar, 20°C
• Tolerance Toleranz Tolérance Tolleranza Tolerancia ±5%

i	Variants	Varianten	Variantes	Varianti	Variantes
KDT 3.60/6	With increased corrosion protection	Mit erhöhtem Korrosionsschutz	Avec protection accrue contre la corrosion	Con una maggiore protezione anti-corrosione	Con el aumento de protección contra la corrosión
KDT 3.60 (SH 13)	In sound proof box SH 13	In Schallhaube SH 13	Dans caisse d'insonorisation SH 13	In casse insonorizzanti SH 13	En caja a prueba de sonido SH 13
KDX 3.60	For x-tra operating hours	Für x-tra Betriebsstunden	Pour le heures de travail x-tra	Per x-tra ore operative	Para las horas de funcionamiento x-tra
	Performance data / dimensions can differ Combinations on request	Leistungsdaten / Abmessungen können abweichen Kombinationen auf Anfrage	Données de performance / mesures peuvent différer Combinaisons sur demande	Dati di performance / misure possono differire Combinazioni su richiesta	Datos de rendimiento / dimensiones pueden diferir Combinaciones a petición